



Powering Business Worldwide

Aerospace Group
Conveyance Systems Division
Carter® Ground Fueling Equipment

SM61657-2

March 1990

APPLICABLE ADDITIONAL MANUALS:

SM60427

SM64348

SM64349

SM64200

SM64201

Maintenance & Repair Manual

Aircraft Adapter Wear Gauge

Model 61657-2

TABLE OF CONTENTS

	<u>PAGE</u>
1.0 INTRODUCTION	3
2.0 EQUIPMENT DESCRIPTION	3
3.0 USE OF GAUGE	3
4.0 MAINTENANCE OF GAUGE	4
5.0 GAUGE REPLACEMENT	4

Maintenance and Instruction Manual

Carter Model 61657-2

1.0 INTRODUCTION

This manual furnishes detailed instructions covering the use and maintenance of Carter Part

Number 61657-2, Aircraft Adapter Wear Gauge.

2.0 EQUIPMENT DESCRIPTION

The Carter Part Number 61657-2 is a "no-go" type gauge designed to determine if an aircraft adapter is safe for use. The nozzle that connects to the aircraft adapter is designed to remain closed unless connected to an adapter and can not be removed from the adapter while in an open condition. This is called the "interlock" function. It is a safety feature paramount in all nozzles. Obviously it could be very dangerous if the interlock feature was nonfunctional and this can occur "if" the nozzle or the adapter are excessively worn. The width of the adapter slots is important to assure that the interlock function of the nozzle is

not defeated. **The Carter nozzle is self checking**, requiring no gauges. Refer to the service manual for the appropriate nozzle for additional safety instructions.

The gauge is furnished with an instruction tag, both of which are hooked to a quick disconnect attachment, so that it is convenient for the operator to carry it on a belt loop having it ready for use at each refueling.

3.0 USE OF GAUGE

The 61657-2 Gauge is furnished for checking three different dimensions on the aircraft refueling adapter whether the adapter is located on an aircraft or used as nozzle storage point. Figures 1 thru 3 illustrate the use of the gauge for all three of these operations. Figure 1 shows the gauge used to check the width of the three slots of the adapter. Figure 2 shows the checking of the lug thickness and Figure 3 illustrates the checking of the lug width.

The gauge is located onto the adapter, near one lug, such that the "Gage Cap" and "Center Pin" are facing away from the adapter. The "Adapter Groove" in the opposite face of the gauge should ride on the rim of the adapter. Two lines are scribed onto the gauge facing the operator to assist the lining up of the groove with the adapter rim. Refer to Figure 1. The Center Pin should protrude outward toward the operator. Slide the gauge around the rim toward to opposite lug until the Center Pin "falls" into the slot. On a good adapter the lining up of the pin with the slot will be evident only by a slight "click" or "indent" feeling. The pin will not move significantly into the slot. With the pin located thus, check to top surface of the Center Pin. It should protrude from the Gage Cap.

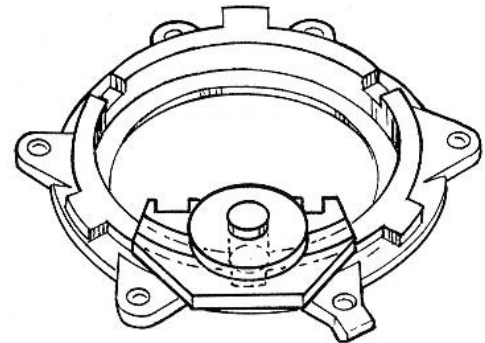

Figure 1
Checking Adapter Slot Width

Repeat the inspection procedure on the remaining two slots. If the Center Pin is flush or below the Gage Cap, the adapter is badly worn and should be replaced at the next convenient time. Refueling of the aircraft may proceed under caution. The following precautions should be taken:

Upon engagement to the aircraft and opening the nozzle but before operating the deadman control, it is recommended that the operator attempt to remove the nozzle from the

aircraft. This should not be possible. If it can be removed, either the nozzle was never fully engaged onto the aircraft or needs repair, or the aircraft adapter is in need of repair. Refueling should not be attempted if the nozzle can be removed while open.

Upon disconnection from an aircraft the nozzle should be inspected to ascertain that all three Index Pins are fully engaged in the cutouts of the Collar Assy. To be certain, it is recommended that the operator squeeze the Lever and Handle Grip together. If this does not make all three Index Pins "pop" into their respective cutouts then the nozzle should be taken out of service for repair. If the pins do "pop" back into place, the aircraft adapter is worn sufficiently to need immediate replacement.

Refer to the appropriate service manual for the particular nozzle to obtain additional information concerning inspection procedures recommended for the nozzle.

3.2 CHECKING ADAPTER LUG THICKNESS

The smaller of the two "notches" provided on the gauge is the one used for this operation. Refer to Figure 2. Attempt to pass the notch across one of the tugs. If the gauge will pass completely across the lug, the adapter needs replacing. Repeat this procedure for all three lugs. Continued use of the adapter is liable to result in a leaking nozzle nose seal.

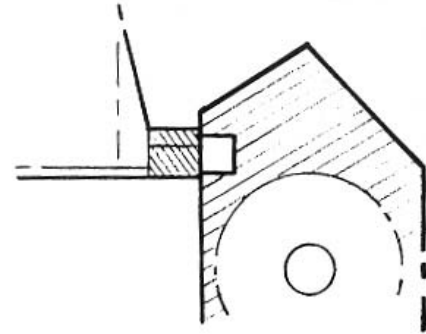

Figure 2
Checking Adapter Lug Thickness

3.3 CHECKING ADAPTER LUG WIDTH

Figure 3 illustrates the use of the gauge to check the width of the adapter lug. If the gauge can be seated onto the lug, the adapter should be replaced at the next opportune time. Repeat the inspection on all three lugs. Refueling of the aircraft can proceed, but only under the cautions noted in paragraph 3.1 above.

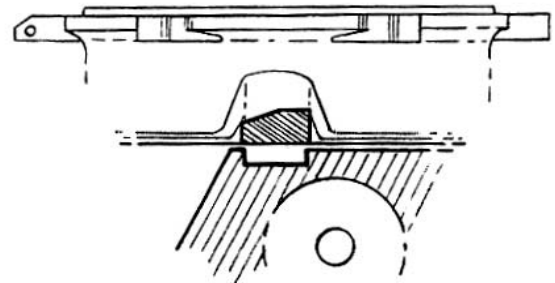

Figure 3
Checking Adapter lug width

4.0 MAINTENANCE OF GAUGE

The Center Pin of the gauge is made of hardened stainless steel, the remainder of relatively softer stainless steel. There should be no source of wear, therefore, on the gauge itself unless it is not properly handled. The width of the two slots should be checked on an annual basis and the pin checked for obvious damage. The wider slot should be .423

to .427 and the narrow slot should be .223 to .227. These dimensions are not being furnished to allow anyone to make a new gauge. Allowance for wear or rough handling has been included within these dimensions.

5.0 GAUGE REPLACEMENT

The 61657-2 Gauge may be procured from any of the authorized Carter Ground Fueling distributors located world-wide.

Aerospace Group
Conveyance Systems Division
9650 Jeronimo Rd
Irvine, CA 92618
Ph (949) 452-9500
Fax (949) 452-9992



Powering Business Worldwide