



Powering Business Worldwide

Aerospace Group
Conveyance Systems Division
Carter® Ground Fueling Equipment

SM61428

October 2006

APPLICABLE ADDITIONAL MANUALS:

SM44315 Quick Disconnect Assy

SM44646 Hose End Regulator

SM47013 Hose End Regulator

SM60129-1 Hose End Regulator

SM428MISC Misc. Adapter Assemblies

SM427MISC Misc. Adapter Assemblies

SM44642 60427 Type QD Assemblies

SM61154 Dry Break Disconnect Assy

SM64001 Quick Disconnect

SM64015 Ball Valve

Maintenance Manual

Pressure Fueling Nozzle

Model 61428

TABLE OF CONTENTS

| | <u>PAGE</u> |
|-------------------------------------|--------------------|
| 1.0 INTRODUCTION | 3 |
| 2.0 EQUIPMENT DESCRIPTION | 3 |
| 3.0 TABLE OF OPTIONS | 3 |
| 4.0 SAFETY INFORMATION..... | 5 |
| 5.0 SPECIAL TOOLS | 8 |
| 6.0 DISASSEMBLY..... | 8 |
| 7.0 INSPECTION | 11 |
| 8.0 REASSEMBLY..... | 11 |
| 9.0 TEST..... | 14 |
| 10.0 ILLUSTRATED PARTS CATALOG..... | 14 |
| | |
| FIGURE 1..... | 17 |
| FIGURE 2..... | 18 |
| FIGURE 3..... | 19 |
| FIGURE 4..... | 20 |

MAINTENANCE, OVERHAUL & TEST INSTRUCTIONS

CARTER PART NUMBER 61428 PRESSURE FUELING NOZZLE

1.0 INTRODUCTION

This manual furnishes detailed instructions covering the maintenance and overhaul of Carter Part Number 61428, Pressure Fueling Nozzle. In this latest issue, the new part numbering system required to identify the nozzle is also fully explained. (See Section 3.0).

For the maintenance of options to the basic 61428 Pressure Fueling Nozzle, refer to Options Table, Section 3.0. This table will reference the service manual that should be used in the maintenance of each option.

2.0 EQUIPMENT DESCRIPTION

The Carter Part Number 61428, Pressure Fueling Nozzle is a 2-1/2 inch underwing fueling nozzle. The basic nozzle would be procured under the part number 61428 which includes the standard handle grips. Other options that are available to build a

nozzle to specific specifications are listed in the table shown in Section 3.0. The exploded view includes options D, E, & R. The Unit is designed to mate with adapters conforming to MS24484 or equivalent.

3.0 TABLE OF OPTIONS AND ORDERING INFORMATION

The following table should be used to determine the service manual to be used in the maintenance, repair or replacement of

parts designated by option letters to the basic 61428 nozzle.

| <u>Option Letter</u> | <u>Part Number</u> | <u>Service Manual</u> |
|----------------------|------------------------|-----------------------|
| B | 44373-60 | SM44315 |
| C | 44373-100 | SM44315 |
| D | 44311 | SM61428 |
| E | 41599 | SM61428 |
| F | 44646-** | SM44646 |
| J | 44509 | SM428MISC |
| R | 207816 | SM61428 |
| T | 44694 | SM428MISC |
| X | 210641 | SM61428 |
| 6, 6H, 6K-P | 44316, 44315-1 thru -6 | SM44315 |
| 7, 7H, 7K-P | 44697, 61554H, K-P | SM61154 |
| 8, 8H, 8K-P | 44701, 61154H, K-P | SM61154 |
| 9, 9H, 9K-P | 44362, 43108-1 thru -6 | SM44642 |

Notes: Nozzles with the old style Dry Break, 44363, were sold under options U-Z to the basic nozzle. Refer to SM44363 for full explanation. The 44363 is out of production and has been superseded by the appropriate 61154 Dry Break.

The older options HH, KK, LL, MM, and PP have been superseded by options 9H, 9K, 9L, 9M and 9P respectively. Refer to SM44642 for full explanation.

The following information will assist in reordering new nozzles to assure one receives the correct item:

The original 61428 Nozzle was furnished with cast in stick handles. Later versions have replaceable stick handles as standard equipment.

The part number of a complete nozzle consists of four basic parts as illustrated below.

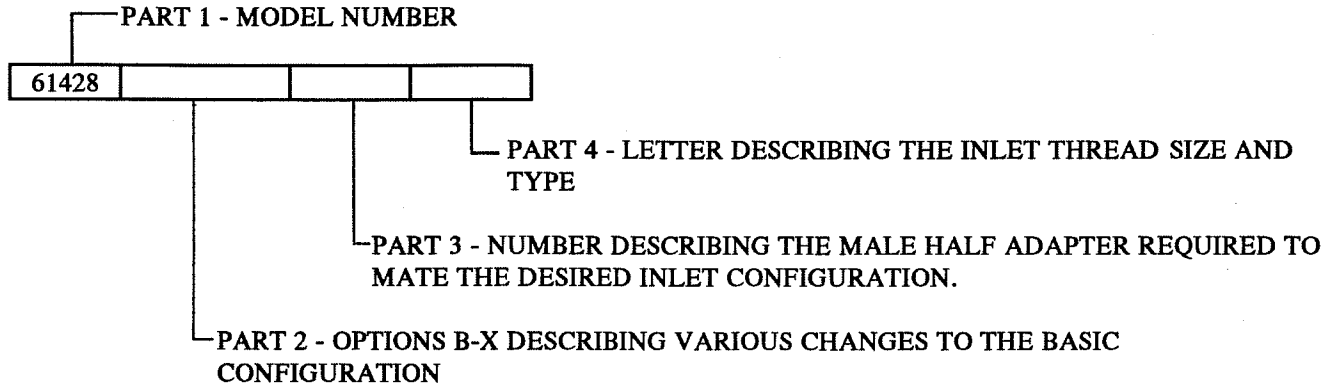

PART 2

The following options may be added as Part 2 of the part number as indicated above to order a unit to meet your requirements:

| OPTION LETTER | DESCRIPTION | OPTION LETTER | DESCRIPTION |
|---------------|---|---------------|--|
| *B | Adds 60-mesh Screen | J | Adds Adapter to allow mating to 60427 Quick Disconnects |
| *C | Adds 100-mesh Screen | R | Adds Circular Handle Grip |
| D | Adds Grounding Cable | T | Adds Adapter to allow mating to Thiem F577/F582 Female inlets |
| E | Adds Vacuum Breaker | ***X | Adds Safety Clip to 61154 Series Dry Break |
| **F3 | Adds 35 psi Hose End Regulator | | |
| **F4 | Adds 45 psi Hose End Regulator | | |
| **F5 | Adds 55 psi Hose End Regulator | | |
| * | Options B & C only available when a male half from Part 3 is specified. | | nearest the inlet. If two regulators with different control pressures are required the higher pressure unit should be specified first. |
| ** | To obtain a nozzle with two regulators, specify two options in series - F5F4 results in 55 and 45 psi units with the 55 psi unit assembled as the one | *** | Can only be ordered in conjunction with Options 7H, 7K-P or 8H, 8K-P. |

PART 3

One of the numbers below must be included as Part 3, as indicated above, to specify the type of inlet configuration desired. The nozzle may be ordered with the inlet terminating in an adapter half only if desired. In this case leave Part 4 blank. If a female half, either quick disconnect or dry break of some configuration is desired, Part 4 must be completed.

ORDERING DATA (Continued)

| OPTION LETTER | DESCRIPTION | OPTION LETTER | DESCRIPTION |
|---------------|---|---------------|--|
| 6 | Adds male adapter half to mate standard quick disconnect (44316) | 8 | Adds male adapter half to mate 61154 Dry Break when used without Regulator (any F option). (44701) |
| 7 | Adds male adapter half to mate 61154 Dry Break when the Regulator is used (any F option). (44697) | 9 | Adds male adapter half to mate with 60427 style quick disconnect. (44362) |

PART 4

One of the following letters must be included as Part 4 as indicated above to specify the inlet thread and size:

| OPTION LETTER | DESCRIPTION | OPTION LETTER | DESCRIPTION |
|---------------|-------------------------|---------------|------------------------|
| H | Inlet thread - 2½" NPT | M | Inlet thread - 3" BSPP |
| K | Inlet thread - 2½" BSPP | N | Inlet thread - 2" BSPP |
| L | Inlet thread - 3" NPT | P | Inlet thread - 2" NPT |

Example: 61428C6H - 61428 Nozzle with 100 mesh screen, standard handle grips and standard quick disconnect with 2½" NPT threaded inlet.

61428BDF4T - 61428 Nozzle with 60 mesh screen, grounding cable, 45 psi regulator, standard handle grips and male adapter half to mate Thiem F577/F582 quick disconnect.

61428F5F4R6K - 61428 Nozzle with 55 psi regulator, 45 psi regulator, circular grip and standard quick disconnect with 2½" BSPP threaded inlet

Note: Early units utilized 44313-** Regulator. Ask for illustrated parts break down IPL44313. The 44313-** is easily distinguished from the newer 44646-** by the color. The

44646-** is black or black with a yellow or alodined stripe while the 44313-** is gold anodized aluminum in color. ** refers to the nominal spring setting, 35, 45 or 55 psi.

4.0 SAFETY INFORMATION

There are several safety interlock features designed into the 61428 Nozzle that must be functioning to prevent an accident that would result in a spill of flammable liquids with the consequential risk of fire, personal injury or death, and property damage. Refer to Table 1.0 to identify individual parts during the following discussion.

4.1 COLLAR ASSY LOCK AND INDEX PINS

Examination of the connection end of a disengaged nozzle (nozzle not connected to an adapter) discloses the three Collar Assy Lock Pins (19) and three Index Pins (21) installed between the Collar Assy (8A) and

the Nozzle Seal (41). Refer to Figure 2. The three spring loaded Collar Assy Lock Pins (19) engage three cutouts (arched shaped windows) in the interior flange of the Collar Assy (8A) when the Collar Assy is in the fully disengaged position. These Collar Assy Lock Pins (19) prevent accidental rotation of the Collar Assy of the disengaged nozzle. One of the three cutouts in Collar Assy (8A) is normally elongated more than the other two.

With the Collar Assy (8A) locked in the disengaged position, the flat portion of a ramp integral to the Collar Assy (8A) is positioned over a flat on the Lever (14) in a manner that prevents opening the Poppet (15).

When connecting to an aircraft, the Index Pins (21) mate with three slots in a serviceable MS24484 Adapter Flange to index the nozzle to the flange so the Collar Assy (8A) mates with the flange lugs during engagement and prevents disengagement of the Collar Assy (8A) from the flange without releasing the three spring loaded Collar Assy Lock Pins (19) to the Collar Assy (8A) lock positions.

4.2 LEVER/COLLAR ASSY INTERLOCK AND OVER CENTER LINKAGE

Examination of the center portion of the Lever (14) on a disengaged nozzle discloses the fact that a flat edge of the Lever (14) is beneath the flat portion of a ramp that is integral to the Collar Assy (8A). With the Collar Assy (8A) locked by the Collar Assy Lock Pins (19), the Collar Assy (8A) ramp prevents rotation of the Lever (14) to the poppet open position. The physical shape of the interlock area of the Lever (14) may vary. On newer nozzles, a ramped "bump" will be apparent. This was added to improve the interlock characteristics of the nozzle. Also on some nozzles a separate wear Plate (8B) made of stainless steel has been added to the Collar Assy (8A) where the Lever (14) tends to interfere. This wear plate is attached by two Screws (8C). The wear plate was added to improve the tolerance condition between the Collar Assy (8A)

and the Lever (14) and to eliminate the potential for galling of aluminum to aluminum. Later versions will not utilize the wear Plate (8B) because the Collar Assy (8A) will be machined to better control tolerances and the Lever (14) will be made of a different alloy, ZA-12, that will not gall on aluminum.

When the Collar Assy (8A) is fully engaged to a serviceable MS24484 Adapter the Collar Assy ramp clears the Lever (14) and permits Lever (14) rotation to the open position.

With the Lever (14) fully open, the round portion of the Lever (14) prevents rotation of the Collar Assy (8A) in the disengage direction until the Lever (14) has been fully closed.

These interlocks are designed to prevent accidental opening of the poppet of a disengaged nozzle or accidentally disengaging a nozzle with the poppet open.

The poppet operating internal linkage design is such that the linkage is "over center" at each extreme of travel (Lever (14) fully open against internal mechanical stop or fully closed against internal mechanical stop).

Thus, internal pressure against a closed poppet, when the linkage is against the closed mechanical stop, provides a force only in the closed direction.

In a similar manner, with the Lever (14) in the fully open/mechanical stop position, the 50 lb. force applied by the MS24484 Adapter Poppet Spring provides a force to maintain the open direction.

4.3 SAFETY INSPECTIONS

Note: The frequencies recommended for the following inspections are our recommendations based on nozzles that have been in daily service for at least a year. The frequency that is required will depend upon the degree of maintenance extended to the equipment and to the age of the equipment.

It is not possible for Carter to recommend other than the safest possible frequencies.

4.3.1 NOZZLE INSPECTIONS - AT EACH REFUELING OPERATION

The following inspections of the Nozzle are recommended at each refueling operation:

A. Inspect the connection end and verify that the Index Pins (21) are intact, in place, and not excessively worn or damaged. Verify that all three Collar Lock Pins (19) are intact, undamaged and are extended and engage all three cutouts in the Collar Assy (8A) and physically prevent Collar Assy (8A) rotation.

This inspection can be accomplished without interruption of the normal operating procedure and without adding appreciably to the operation time by training the operator to automatically observe the connection end of the nozzle upon disconnection from the aircraft. If the Collar Lock Pins (19) are not extended and engaged in all three cutouts in the Collar Assy (8A), the operator should squeeze the Lever (14) and Handle Grip (4) together while observing the connecting end of the nozzle. This should cause the Collar Lock Pins (19) to "spring" into the cutouts in the Collar Assy (8A). If not, then the nozzle should be taken out of service. If the Collar Lock Pins (19) do not spring into their correct position, it could mean that the aircraft adapter is defective and should be inspected (see paragraph 4.3.3) and reported as possibly being defective.

B. Upon engagement to an aircraft and opening the nozzle but before operating the deadman control it is recommended that the operator attempt to remove the nozzle from the aircraft. This should not be possible. If it can be removed, either the nozzle was never fully engaged onto the aircraft or needs repair, or the aircraft adapter is in need of repair or replacement.

4.3.2 NOZZLES INSPECTIONS - MONTHLY BASIS

The following inspections of the Nozzle are recommended to be conducted on a monthly basis as a minimum:

A. Inspect the connection end and verify that the three Index Pins (21) are intact and in place. Verify that the three Collar Assy Lock Pins (19) are intact and in place and extended and engaging all three cutouts in the Collar Assy (8A) and physically preventing Collar Assy (8A) rotation. Check the Bearing Plate (42) containing the pins for possible cracks.

B. Hold the nozzle with the outlet or connecting end facing such that it can be observed. Apply pressure on the Collar Assy (8A) in the direction to connect the nozzle aircraft, counterclockwise, to take up the slack and inspect the relative location of the three Lock Pins (19) with respect to the cutouts in the Collar Assy (8A). The two Lock Pins (19) that are engaged in the normally narrower cutouts should be resting against the edge of their respective cutouts. If there is a space between the third Index Pin (19) and the edge of the normally larger cutout, the collar is still in functional condition. If all three Lock Pins (19) are resting against the edge of their respective cutouts (there is no space), the Collar Assy (8A) may no longer be in a functional condition and should be replaced if it fails the next step.

C. With the nozzle being held in the position described above, attempt to open the nozzle with the Lever (14). The nozzle should be prevented from opening by the interference between the Collar Assy (8A) and the Lever (14). If the nozzle is openable, it should be removed from service and repaired.

D. Inspect the Lever (14) and the adjacent ramp surface of the Collar Assy (8A) and verify that neither part is damaged or has missing pieces that permit the Lever (14) to be rotated to the open position with the nozzle disengaged or that will allow the Collar Assy (8A) to rotate to the disengaged position when the Lever (14) is open. Some nozzles have a stainless steel

wear Plate (8B) affixed by two Screws (8C) as a part of the Collar Assy (8A) at the point of contact with the Lever (14). Ascertain that it is not missing or loose. If there are no threaded holes for the Plate (8B) then it is not required. Broken or missing parts can result in dangerous fuel spills while refueling aircraft.

E. Verify that the Lever (14) is in the fully closed (against internal mechanical stop) position. (This is necessary to assure that the linkage is over center so internal pressure can not force the poppet open during the Collar Assy (8A) engagement).

4.3.3 AIRCRAFT ADAPTER INSPECTIONS

The following inspections of the aircraft adapter are recommended to be carried out at each refueling operation to assure that one is connecting to a safe adapter:

A. Visually check for bent, broken, missing or excessively worn lugs or slots. Worn slots are easily detected. A normal slot will have a slight machine broken edge (chamfer of .030 inch (0.762 mm)). If the

edge is worn such that the corner is badly distorted and enlarged it should be inspected more closely and accurately. Carter Adapter Wear Gauge, 61657-2, should be utilized to check the width and thickness of the lugs if they appear to be worn. Wear of the thickness dimension of the lug will promote premature nose seal leakage. Wear of the width of the lug combines with slot wear in defeating the nozzle interlock.

B. Visually check the three slots for excessive wear. Excessive wear can permit disengagement of a nozzle without release of the three Collar Assy Lock Pins (19) and may permit accidental poppet opening on the disconnected nozzle. The use of Carter Gauge 61657-2 will provide a "no-go" check for the slots.

C. If any of the above conditions are observed, and or the gauge proves the adapter to be defective, the refueling operation should be continued only with extreme caution. The nozzle, upon disconnection, should be checked in accordance with paragraph 4.3.1.A.

5.0 SPECIAL TOOLS

The following special tools are recommended for proper repair and or overhaul of the nozzle:

- * S204451 - Standard three lug bayonet adapter flange or equivalent.
- * 6958CG or 6958CH Adapter or equivalent.

- * 61657-2 Adapter Wear Gauge
- * 64000 Poppet Adjustment Gauge
- * 61607 Ball (10 & 11) Assembly Tool

The above items are available from your Carter distributor.

6.0 DISASSEMBLY

6.1 Remove nozzle from end of hose at quick disconnect. Refer to appropriate service manual depending upon type of swivel disconnect utilized.

- SM44315..... Standard 61428 Nozzle Swivel Disconnect
- SM44642..... 60427 Style Quick Disconnect

- SM44363..... Old Style Dry Break Quick Disconnect
- SM428MISC.. Adapter Assemblies to mate Thiem F116.F117 and Carter 60427 Nozzle Quick Disconnects.
- SM61154..... New Style Dry Break Quick Disconnect

6.2 Screw (23) is a self-locking type screw that utilizes a nylon insert in the threads to affect the resistance required to provide the locking. They are designed to be reused a minimum of 15 times before losing their locking effectivity. Using a torque wrench, remove Screw (23) and O-ring (24) from lower half of Body (9), measuring the torque during removal. If the torque is less than 9.5 in lbs (0.11 m kg) discard the screw and replace it with a new one during reassembly. If Ball Assy Tool 61607 is available, screw it into the boss from which Screw (23) was removed. Hold the nozzle such that the Tool is below the nozzle and rotate the Quick Disconnect Adapter (46-48, 54, 56 or 57) or Regulator (45) until all Balls (11) have been captured in the Tool. The correct amount of Balls (11) will be captured when the level of Balls (11) reaches the line scribed on the tube of the Tool. If the Tool is not utilized, remove Balls (11), 39 each, from Unit by hand. Hold bolt hole vertical (pointed down) and allow all ball bearings to fall through the bolt hole. Catch all balls in a container. Some rotation between the Body (9) and the attached Adapter or Regulator may be required to allow 39 Balls (11) to fall out of hole. Remove the Adapter or Regulator (refer to appropriate Service Manual). Note that the Spring (12) and Pin (13) located between the Body (9) and Adapter may fall out loose. On later models, these two parts have been replaced with a single Clip (12A) which will not fall out of the hole in the Body (9). It is recommended that the two parts, if present, be replaced with the newer Clip (12A) when available. Either the Clip (12A) or the Spring (12) and Pin (13) are required for electrical conductivity between the two parts. If Clip (12A) is to be replaced, use a pair of needle nose pliers to grasp the existing part and pull it from the hole in the Body (9). See Figure 4. Clear the hole of any debris.

Remove O-Ring (25) from internal groove in the inlet of the Body (9).

6.3 Some nozzles have the handle Grips (4) or (6) attached by an adhesive and some utilize the self-locking Screw (4B) and Washer

(4A). To remove the Cover (1) it is necessary to remove the appropriate Grips (4) or (6). If the Cover (1) is in good condition it is not necessary to remove it at this time. Leave it attached to the handle. If replacement of the Cover (1) is required and the Grips (4) or (6) are not attached by Screw (4B), first try removing the Grip (4) or (6) by inserting it in a vise and applying a rotational force to break loose the glue used to install it. If this is not possible or the Grip (4) or (6) is in such condition that it needs replacing it should be removed by cutting it off of the metal handle. It is attached with a super glue. If the Screw (4B) is used it should be removed with a torque wrench and the removal torque measured. This screw is a self-locking type and is designed to be reused up to 15 times before losing its locking capability. If the torque is less than 6.5 in-lbs discard it and replace it during reassembly.

Remove the Bumper (5) only if replacement is necessary by cutting through it.

6.4 Screw (7) is a self locking type screw that utilizes a nylon insert in the threads to affect the resistance required to provide the locking. Self locking screws are designed to be reused a minimum of 15 times before losing their locking effectivity. Using a torque wrench, remove Screw (7) from Collar Assy (8A), measuring the torque during removal. If the torque is less than 9.5 in lbs (0.11 m kg) discard the screw and replace it with a new one during reassembly. Remove the Balls (10) from the bolt hole in the manner described in paragraph 6.2 above. There are 49 balls in this joint. The correct number of Balls (10) will be removed when the level in the Tool reaches the line created by the brass fitting that screws into the Collar (8A). If the Tool is not utilized, store the Balls (10) in a separate container for cleaning and replacement later.

6.5 Engage the nozzle to the S204451 flange (any standard aircraft three-lug locking flange).

6.6 While removing Collar Assy (8A) from Body (9) Spring (12) and Pin (13) trapped between them may tend to fly out and get lost. These may not be present in later units. They were in place to assure electrical conductivity between the Collar Assy (8A) and Body (9). Later tests prove that these items are no longer required. If present discard them. Remove Collar Assy (8A) from Body (9) by aligning the groove in the Collar Assy (8A) with detent on Body (9) and pull Body (9) from Collar Assy. Collar Assy (8A) may have wear Plate (8B) affixed by two Screws (8C). Do not remove the Plate (8B) unless it needs replacement. Some nozzles may not have nor need this wear Plate (8B). If there are no provisions for it (threaded holes), it is not needed. However, if the two holes do exist, a wear Plate (8B) should be used.

Some nozzles, Option U, will have stick Handles (8E) that are replaceable. Remove these Handles (8E) only if replacement is needed.

6.7 Remove S204451 Adapter.

6.8 Turn Lever (14) to open Poppet (15).

6.9 Earlier nozzles (prior to serial number 2,000) utilized a "disc-lock" (Washer (16)) and jam Nut (39) to hold the Poppet (15) and locked to the Shaft (32). For instructions on this type of assembly proceed to paragraph 6.10.1.

Nozzles with serial numbers greater than 1,999 utilize a cotter Pin (26) to lock the Poppet Assy (15A) onto the Shaft (32A). The Poppet Assy (15A) is an anodized aluminum alloy color and is not Teflon coated (green). For instructions on this type of assembly skip to paragraph 6.10.2.

6.9.1 Nozzles with Poppet (15) and Shaft (32) assembled and locked in place with Nut (39) and Washers (Disc-Lock type) (16) -**Before proceeding further, read the Caution below.** Loosen Nut (39) until the ramps (see Figure 3 - Detail) of the two Washers (16) begin to ride up each other, then gently turn the Nut (39) back until the ramps have

nested again without torquing the nut. Now, using a wrench on the Nut (39) and a hand on the Poppet (15), rotate the Nut (39), Washers (16), Poppet (15), and Shroud (17) off the Shaft (32) as an assembly.

CAUTION

Because of the anti-vibration design of the Washers (16), do not attempt to completely back off the Nut (39) or remove the Poppet (15) by themselves. This would require excessive torque which can result in damage to the shaft and linkage assembly internally within the nozzle.

6.9.2 Remove Cotter (26) and unscrew the Poppet Assy (15A) from the Shaft (32A).

6.10 The Nozzle Seal Assembly (40) may be removed by lifting off Body (9). The Plate (42) may be removed from the Seal (41) by spreading the ends of the Retaining Ring (43), removing it from the groove in the Seal (41) and then sliding the Plate (42) off the Seal (41).

6.11 The three Lock Pins (19), three Lock Pin Springs (20), three Index Pins (21) and O-Ring (18) may now be removed.

6.12 Hold the Body (9) with the outlet in an upward position. Rotate it until the two pipe Plugs (22) are visible. Remove the left hand Plug.

NOTE: Use new Teflon tape on reinstallation. Do not utilize more than 1 1/2 wraps of tape. Excessive use of tape could lead to the cracking of the Body (9).

6.13 Remove Screws (35) through plug opening (22). **Observe the orientation of the Plate (36) with respect to the Lever (14) such that it can be duplicated during reassembly. Mis-orientation will result in not being able to close the nozzle properly.**

6.14 Remove Lever (14) from Body (9). Remove Seal (37) and Backup Ring (38) from Lever (14).

- | | | | |
|------|---|------|--|
| 6.15 | Remove assembled Shaft (32 or 32A), Pin (33), Link (34) and Plate (36) from Body (9). | 6.17 | Do not remove Cable (44), option D only, unless replacement is required. The mounting screw is included with the new replacement assembly. |
| 6.16 | Remove Pin (33). Disassemble Cotter Pin (29), Nut (30) and Crank Pin (31) only if replacement is necessary. | 6.18 | On option E only, remove the Vacuum Breaker (53) only if replacement is required. The Vacuum Breaker (53) is not economical to repair and should be replaced, if needed, as a complete assembly. |

7.0 INSPECTION

It is recommended that all O-rings (18), (24), (37) and (25), Back-up (38), Nose Seal (41) & Cotter Pins (26) & (29) (if it is disassembled) be replaced upon every overhaul. Inspect all metal parts for dings, gouges, abrasions, etc. Use 320 grit paper to smooth and remove sharp edges. Replace any part with damage exceeding 15% of local wall thickness. Use alodine 1200 to touch up bared aluminum. Precisely measure the following items. Replace any part that exceeds the identified maximum or minimum wear limits:

- * Both holes in item 30 Link (.196 inch (4.98 mm) diameter max & .320 inch (8.13 mm) diameter max).
- * Bearing diameter of item 31 Pin (.300 inch (7.62 mm) diameter min).
- * Tapered bearing diameter of item 14 Lever (.697 inch (17.7 mm) diameter

min on large end & .635 inch (16.1 mm) diameter min on small end).

Check the ball race (internal groove that mates the Balls (10)) inside the Body (9) for raised burrs or buildup of material that may prevent the disassembly of the mating Adapter. The corner of the ball race should be a smooth radius no greater than .03 inches (.76 mm). The raised burr may be removed with appropriate abrasive. If it is too large to remove in this manner, replace the body.

Check the ball race located inside the Collar Assy (8A) for raised burrs in the same manner as above.

Check the external ball race on the large OD of the Body (9) in the same manner as above.

Roll Pin (21) on a flat surface to check for straightness. Replace any suspect pin.

8.0 REASSEMBLY

- 8.1 Reassemble in reverse order of disassembly (Refer to Figure 2), observing the following:
- 8.1.1 Make certain all components are clean and free from oil, grease, or any other corrosion

resistant compound on all interior or exterior surfaces. Wash all parts with cleaning solvent, Federal Specification P-D-680 or equivalent, and dry thoroughly with a clean, lint-free cloth or compressed air.

WARNING:

Use cleaning solvent in a well-ventilated area. Avoid breathing of fumes and excessive solvent contact with skin.
Keep away from open flame

DO NOT use any form of grease on Balls (10) or (11) and be certain to install proper number of balls in each hole of Body (9) and collar assembly. The use of Tool 61607 will facilitate the counting and assembly of the Balls (10 or 11) back into the unit. Also make sure that Pin (13) and Spring (12) or Clip (12A) is installed properly to maintain continuity through the unit. Refer to Figure 4 for installation information.

NOTE: A light coat of petrolatum, Federal Specification VV-P-236 or equivalent commercial quality, can be applied to all o-rings, springs, and screws for ease of installation.

- 8.1.2 If Cotter (29) and Nut (30) were removed during disassembly, torque Nut (30) to 80 - 125 in lbs to align slots in nut with hole in Crank Pin (31). When reinserting the sub-assembled parts noted in Para. 6.16 of the disassembly procedure, through the inlet end of the Body (9), ensure that the Shaft (32) or (32A) is inserted into the Body's (9) axial guide bore far enough that the bore contains the Dowel Pin (33). Assure that the orientation of the Plate (36) to the Lever (14) is as observed prior to disassembly. Use the 9/64 inch allen wrench through the Body's (9) pipe thread port to secure the Plate (36) to the end of the Lever (14) shaft with the four socket head Screws (35). Torque each of the Screws (35) to 16 to 18 inch pounds above the torque required to rotate the screws in the thread locking inserts installed in the Lever (14) end.

Should it be desired to be able to change the nose seal of the nozzle without a major disassembly of the unit it is possible to do by eliminating Snap Ring (43). One word of caution should this be done. If the nozzle is opened with a tool that does not have the characteristic lugs of an adapter, the nose seal may follow the poppet open and be difficult to reinstall without disassembly. The Snap Ring (43) will continue to be installed by the factory. When the nose seal is to be replaced, please refer to the Caution Note in paragraph 6.9.1 before proceeding.

- 8.1.3 Earlier nozzles (prior to serial number 2,000) utilized a "disc-lock" Washer (16)

and jam Nut (39) to hold the Poppet (15) locked onto the Shaft (32). For instructions on this type of assembly proceed to paragraph 8.1.3.1.

Nozzles with serial numbers greater than 1,999 utilize a cotter Pin (26) to lock the Poppet Assy (15A) onto the Shaft (32A). For instructions on this type of assembly skip to paragraph 8.1.3.6.

- 8.1.3.1 Connect Nozzle to S204451 flange when installing the poppet (15). Use the Lever (14) to operate the Shaft (32) to the fully retracted position. Then install the Nut (39) to the Shaft (32) with the nut's flat face out. Run the Nut (39) down the retracted Shaft (32) with the fingers until stopped by the base of the Body (9) bore. Then loosen the Nut (39) one quarter (1/4) turn. Then use the Lever (14) to fully extend the Shaft (32) without disturbing the Nut (39).
- 8.1.3.2 Install the two Disc Lock Washers (16) on top of the Nut (39) so that the ribs will contact the Nut (39) and the Poppet (15) and Shroud (17). The ramps on the two Washers (16) should be engaged (See Figure 3, Detail).
- 8.1.3.3 Place Shroud (17) on Shaft (32) with the flared end facing out. Screw the Poppet (15) to the Shaft (32) approximately 4 to 4 1/2 complete revolutions. Be sure that the Shroud (17) is nested in the counterbore on the Poppet (15) before the Poppet (15) contacts the Disc-Lock Washers (16). Use the Lever (14) to fully close the Poppet (15). If excessive resistance prevents closing the Poppet (15), progressively attempt closing the Poppet (15) after unscrewing the Poppet (15) in one quarter (1/4) turn increments). If this doesn't prevent the excessive resistance to closing check to be sure that the Nut (39) is not interfering with the center shaft support of the Body (9).
- 8.1.3.4 With the Poppet (15) closed, disengage the Collar Assy (8A) from the S204451 Flange and set the nozzle on its inlet end. Use Poppet Adjustment Gauge, 64000, to facilitate the adjustment of the Poppet (15)

onto the Shaft (32). Follow instructions furnished with the gauge. If the gauge is not used, place a straight edge across the center of the elastomer lip of the Seal (41). Use feeler gages to measure the average dimension between the bottom of the straight edge and the Poppet (15) face. This dimension should be .070 to .110 inch (1.8 to 2.8 mm). If it is not, calculate the required poppet dimension as follows: (one quarter (1/4) turn of the Poppet (15) axially displaces the Poppet (15) face about .020 inch (0.51 mm).

A. If the feeler gage measurement is too long, prepare to unscrew (loosen) the Poppet (15) one quarter (1/4) turn for each .020 (0.51 mm) inch of required adjustment.

B. If the measurement is too short, prepare to tighten the Poppet (15) one quarter (1/4) turn for each .020 (0.51 mm) inch of required adjustment.

8.1.3.5 Re-engage the S204451 Flange to the Collar Assy (8A) and reopen the Poppet (15). Make any Poppet (15) adjustments determined to be necessary by Para. 8.1.3.4, step A or B. Recheck the measurement denoted in Paragraph 8.1.3.4 above. Tighten the Nut (39) by hand against the Disc Lock Washers (16) and the Poppet (15). Check to ensure that Shroud (17) is installed properly and not cocked to one side. While holding the Poppet (15) clamped in a wooden vice, being careful not to damage sealing surface, torque the Nut (39) to 200 ± 10 lb. inch. Operate the Poppet (15) fully open to fully closed to fully open several times. Then close the Poppet (15) and disengage the S204451 Flange.

8.1.3.6 Use the Lever (14) and move the Shaft (32A) to its fully extended (open) position to install the Poppet Assy (15A).

Before inserting the Cotter (26), adjust the Poppet Assy (15A) to approximately .020 to .040 inch (.508 to 1.016 mm) above the top of the face of the Collar (8A). Use Poppet Adjustment Gauge 64000 to facilitate the

adjustment. If the gauge is not available, utilize a straight edge and a feeler gauge as described in paragraph 8.1.3.4 above.

8.1.3.7 Once the proper Poppet Assy (15A) adjustment is made, rotate the Poppet toward the tightening direction until the next slot in the Poppet Assy (15A) is in line with the hole in the Shaft (32A). Insert the Cotter (26) and bend over the ends to retain in place.

8.2 If the Grip (4) or (6) requires replacing due to wear or the replacement of the Cover (1), the new Grips (4) or (6) shall be reinstalled observing the following:

8.2.1 If there are no provisions for using Screw (4B) and Washer (4A) to attach the Grip, use steel wool or other abrasive to thoroughly clean the aluminum handle onto which the Grip (4) or (6) fits. All traces of the old Grips (4) or (6) must be removed and the handle should be shiny.

8.2.2 Apply a band of Adhesive (3) to the inside diameter of the new Grips (4) or Circular Handle (6) and to the end and to the top one inch of the aluminum handle, slide the Grip (4) or Circular Handle (6) onto the aluminum handle until it is seated in its fully on position. Note that the Grip (4) does not slide to its full length onto the metal handle. A length of the Grip (4) is purposely left unsupported by the metal handle to help absorb handling shocks. A light tapping of the Grip (4) with a rubber mallet may be necessary to seat it. **DO NOT** handle for at least ten minutes to allow initial setup curing. The adhesive will be fully cured within 24 hours. If the end of the handles are threaded install the Grip (4) or Handle (6) using Screw (4B) and Washer (4A). If one desires to rework a handle that does not have the threaded holes, have each handle drilled and tapped, on center, by tap drilling 1.00 inches deep and tapping .3125-18 UNC-2B by .75 inches deep.

8.3 If Bumper (5) is to be replaced onto Collar Assy (8A) warm Bumper (5) in water at 160-180° F to soften before pressing onto Collar Assy (8A).

- 8.4 If stick Handles (8E) were removed for replacement they should be reassembled to Collar (8D) using the appropriate Screws (8F), Washers (8G) and Nuts (8H). Tighten to secure Handles (8E) into place in the Collar (8D).

9.0 TEST

- 9.1 The following test procedures will be accomplished after overhaul: binding or excessive force required for valve actuation.
- 9.2 Test conditions
 Test media shall be Stoddard Solvent (Federal Specification P-D-680), JP-4 per MIL-J-5624D at 75° ± 15° F, Jet A or equivalent.
- 9.3 Functional Test
- 9.3.1 The nozzle shall be inserted and locked into a test adapter, Carter 6958CG or CH or equivalent and the nozzle valve actuated by use of the crank Lever (14) from the fully closed to fully open position a minimum of five times. There shall be no evidence of
- 9.4 Leakage Test
- 9.4.1 With the nozzle outlet in the normal open position, and the test adapter outlet closed, pressurize the inlet to five PSIG and hold for one minute minimum. There shall be no evidence of external leakage from the nozzle.
- 9.4.2 Repeat the leakage test at 60 PSIG and 120 PSIG.
- 9.4.3 Close and disengage the nozzle and repeat 9.4.1 and 9.4.2.

10.0 ILLUSTRATED PARTS CATALOG

Table 1.0 tabulates the parts and sub-assemblies comprising the 61428 Pressure Fueling Nozzle. The item numbers of the

table are keyed to the exploded views of the nozzle diagramed in Figure 1, 2 and 3.

TABLE 1.0

| <u>Item</u> | <u>Part Number</u> | <u>Description</u> | <u>Units Per Assembly</u> | <u>Nozzle Option</u> | <u>Spares/10 Units/Yr</u> |
|-------------|---------------------------|---------------------------------|---------------------------|----------------------|---------------------------|
| 1 | 207799 | Cover | 1 | All | 10 |
| 2 | Left intentionally blank. | | | | |
| 3 | 447 | Loctite Adhesive (Note 1) | A/R | Note 1 | - |
| 4 | 207808 | Grip | 2 | All but R | 5 |
| 4A | GF960-516 | Washer | 2 | All | 5 |
| 4B | GF16997-78L | Cap Screw | 2 | All | 5 |
| 5 | 23622 | Bumper | 1 | All | 3 |
| 6 | 207816 | Circular Handle (Note 2) | 1 | R | 2 |
| 7 | 220484 | Screw, Cap (Note 3) | 1 | All | - |
| 8A | 44309 | Collar (Note 4) | 1 | Note 16 | - |
| 8B | 209403 | Plate (Note 4) | 1 | Note 4 | - |
| 8C | LP51957-26 | Screw (Note 4) | 2 | Note 4 | - |
| 8D | 210592 | Collar | 1 | Note 16 | - |
| 8E | 210600 | Handle | 2 | Note 16 | - |
| 8F | GF4-13A | Screw | 2 | Note 16 | - |
| 8G | GF960-416 | Washer | 4 | Note 16 | - |

| <u>Item</u> | <u>Part Number</u> | <u>Description</u> | <u>Units Per Assembly</u> | <u>Nozzle Option</u> | <u>Spares/10 Units/Yr</u> |
|-------------|--------------------------|---|---------------------------|----------------------|---------------------------|
| 8H | GF21042-4 | Nut | 2 | Note 16 | - |
| 9 | 207784 | Body..... | 1 | All | - |
| 10 | 82123 | Bearing, Ball | 49 | All | - |
| 11 | 82123 | Bearing, Ball | 39 | All | - |
| 12 | 82153 | Spring | 1 | All | 4 |
| 12A | 209853 | Clip..... | 1 | All | 1 |
| 13 | D5-187 | Pin..... | 1 | All | 4 |
| 14 | 207785 | On/Off Act. Lever | 1 | All | - |
| 15 | 209097 | Poppet (Use with 16, 17, 32 & 39 only) 1 | 1 | All | - |
| 15A | 210593 | Poppet (Use with 26 & 32A only)..... | 1 | All | - |
| 16 | 106-20 | Washers (Use with 15, 17, 32 & 39 only)2 | 2 | All | - |
| 17 | 209190 | Shroud (Use with 15, 16, 32 & 39 only) 1 | 1 | All | - |
| 18 | M25988/1-145 | O-Ring | 1 | All | 10 |
| 19 | 207789 | Pin, Collar Lock..... | 3 | All | - |
| 20 | 20909 | Spring, Collar Lock Pin (Note 13) | 3 | All | - |
| 21 | 24780 | Pin, Indexing | 3 | All | - |
| 22 | GF27769D4 | Plug | 2 | All | - |
| 23 | 209827 | Screw, Cap (Note 5)..... | 1 | All | - |
| 24 | MS29512-03 | O-ring (Note 5)..... | 1 | All | 10 |
| 25 | M25988/1-235 | O-Ring | 1 | All | 10 |
| 26 | GF24665-302 | Pin, Cotter (Use w/15A,17A & 32A only)1 | 1 | All | 5 |
| 27-28 | Left intentionally blank | | | | |
| 29 | GF24665-1013 | Pin, Cotter..... | 1 | All | 5 |
| 30 | GF320C4 | Nut Castellated | 1 | All | - |
| 31 | 207788 | Pin, Crank..... | 1 | All | - |
| 32 | 208829 | Shaft (Use with 15, 16, 17 and 39 only) 1 | 1 | All | - |
| 32A | 210368 | Shaft (Use with 15A & 26 only)..... | 1 | All | - |
| 33 | D9-437 | Dowel Pin | 1 | All | - |
| 34 | 207795 | Link | 1 | All | - |
| 35 | GF16995-28 | Screw..... | 4 | All | - |
| 36 | 207783 | Plate | 1 | All | - |
| 37 | 207792 | O-Ring TFE Coated | 1 | All | 10 |
| 38 | M25988/1-017 | Back-Up | 1 | All | 10 |
| 39 | 209109 | Nut, Jam (Use with 15,16, 17 & 39 only)1 | 1 | All | - |
| 40 | 44574 | Nose, Seal Assy | 1 | All | - |
| 41 | 209029 | Seal, Nozzle | 1 | All | 10 |
| 42 | 24779 | Plate, Bearing | 1 | All | - |
| 43 | 24636 | Ring, Snap..... | 1 | All | - |
| 44 | 44311 | Cable Assy (Note 6) | 1 | D | - |
| 45 | 44646-* | Regulator (Note 7) | - | F3,F4,F5 | - |
| 46 | 44362 | QD, Male Half (Note 8) | - | 9 | - |
| 47 | 44316 | QD, Male Half (Note 9) | - | 6 | - |
| 48 | 44694 | QD, Male Half (Note 12)..... | - | T | - |
| 49 | 44373-** | Screen Assy (Note 9) | - | B,C | - |
| 50 | 44317-* | QD, Female Half (Note 9)..... | - | 6H,K,L-N,P | - |
| 51 | 43108-* | QD, Female Half (Note 10) | - | 9H,K,L-N,P | - |
| 52 | 44363-* | QD, Dry Break Female..... | - | Note 8 | - |
| 53 | 41599 | Vacuum Breaker (Note 11) | 1 | E | - |
| 54 | 44509 | Adapter Assy (Note 12) | - | J | - |
| 55 | 61428 or 61428U | Nozzle..... | - | All | - |
| 56 | 44697 | Short Male Adapter Assy | - | 7 | - |
| 57 | 44701 | Long Male Adapter Assy | - | 8 | - |
| 58 | 61154H | Dry Break Assy, 2½ NPT | - | 7H, 8H | - |

| <u>Item</u> | <u>Part Number</u> | <u>Description</u> | <u>Units Per Assembly</u> | <u>Nozzle Option</u> | <u>Spares/10 Units/Yr</u> |
|-------------|--------------------|--|-------------------------------|--------------------------|-------------------------------|
| | 61154K | Dry Break Assy, 2½ BSPP | - | 7K, 8K | - |
| | 61154L | Dry Break Assy, 3 NPT | - | 7L, 8L | - |
| | 61154M | Dry Break Assy, 3 BSPP | - | 7M, 8M | - |
| | 61154N | Dry Break Assy, 2 BSPP | - | 7N, 8N | - |
| | 61154P | Dry Break Assy, 2 NPT | - | 7P, 8P | - |
| 59 | 210641 | Safety Clip (Note 15) | 1 | X | - |
| -- | KD61428-1 | Seal Kit - Contains items 12A, 18, 24, 25, 26, 41 & 37. | | | |
| -- | KD61428-2 | Seal Kit for 614289H, 9K, 9L, 9M, 9N or 9P - Contains all in -1 Kit (except item 12A) plus M25988/1-040 O-ring, 207807 Seal & 201201-231 O-ring. | | | |
| -- | KD61428-3 | Seal Kit for 61428T. Contains -2 Kit plus 210174-231 Quad Ring instead of the 201201-231 O-ring. | | | |
| -- | KD61428-4 | Seal Kit for 614286H, 6K, 6L, 6M, 6N or 6P. Contains -2 Kit plus 210174-337 Quad-ring instead of the 201201-231 O-ring. | | | |
| -- | KD61428-5 | Seal Kit for 44646 Regulator only. See SM44646 for content. | | | |
| -- | KD61428-6 | Seal Kit for Old Style Dry Break with 61428. Contains -2 Kit plus 201201-233 O-ring. | | | |
| -- | KD61428-7 | Seal Kit for 61428 with New Style Dry Break, 61154. Contains -2 Kit less 201201-231 O-ring but including the seals for the 61154. See SM61154 for applicable seals | | | |
| - | KD61428-8 | Shaft and Poppet kit to upgrade disc-lock type locking to cotter pin type. Contains items 15A, 26 and 32A. | | | |

Notes:

1. Adhesive is used only on units that do not have items 4A and 4B.
2. Used with Option R only.
3. Older units may have part number 209827 Screw in place. When ordering replacement part, use part number 220484.
4. Earlier units did not include items 8B & 8C as mentioned earlier in the text. Part number without items 8B and 8C remains as 44309.
5. Earlier units used either MS24678-41C and 600-015-3/8 or T-1191 and 5-058N674-70 in lieu of items 23 and 24 respectively. Both of the seals, 600-015-3/8 and 5-058N674-70 will be available as spare parts for several years, however it is strongly recommended that any units using the MS24678-41C Screws be upgraded to the new Screw (7) or (23) to prolong the life of the Body (9).
6. Used with Option D only.
7. Refer to SM44646 for detail information.
8. Old Style Dry Break no longer available. Refer to SM44363 for detail information.
9. Refer to SM44315 for detail information.
10. Refer to SM40679 for detail information.
11. Used with Option E only.
12. Refer to SM428MISC for detail information.
13. 20909 interchangeable with previous part number 207790.
14. All part numbers beginning with "GF" are interchangeable with those beginning with either "AN" or "MS". If the "GF" is followed by three numbers it is interchangeable with and "AN" part, otherwise it is interchangeable with an "MS" part of the same number.
15. Used with Option X only.
16. 44309 Collar utilized on all nozzles with cast-in handles. If replacement is necessary, replace with items 8D-8H in quantities shown for each nozzle.

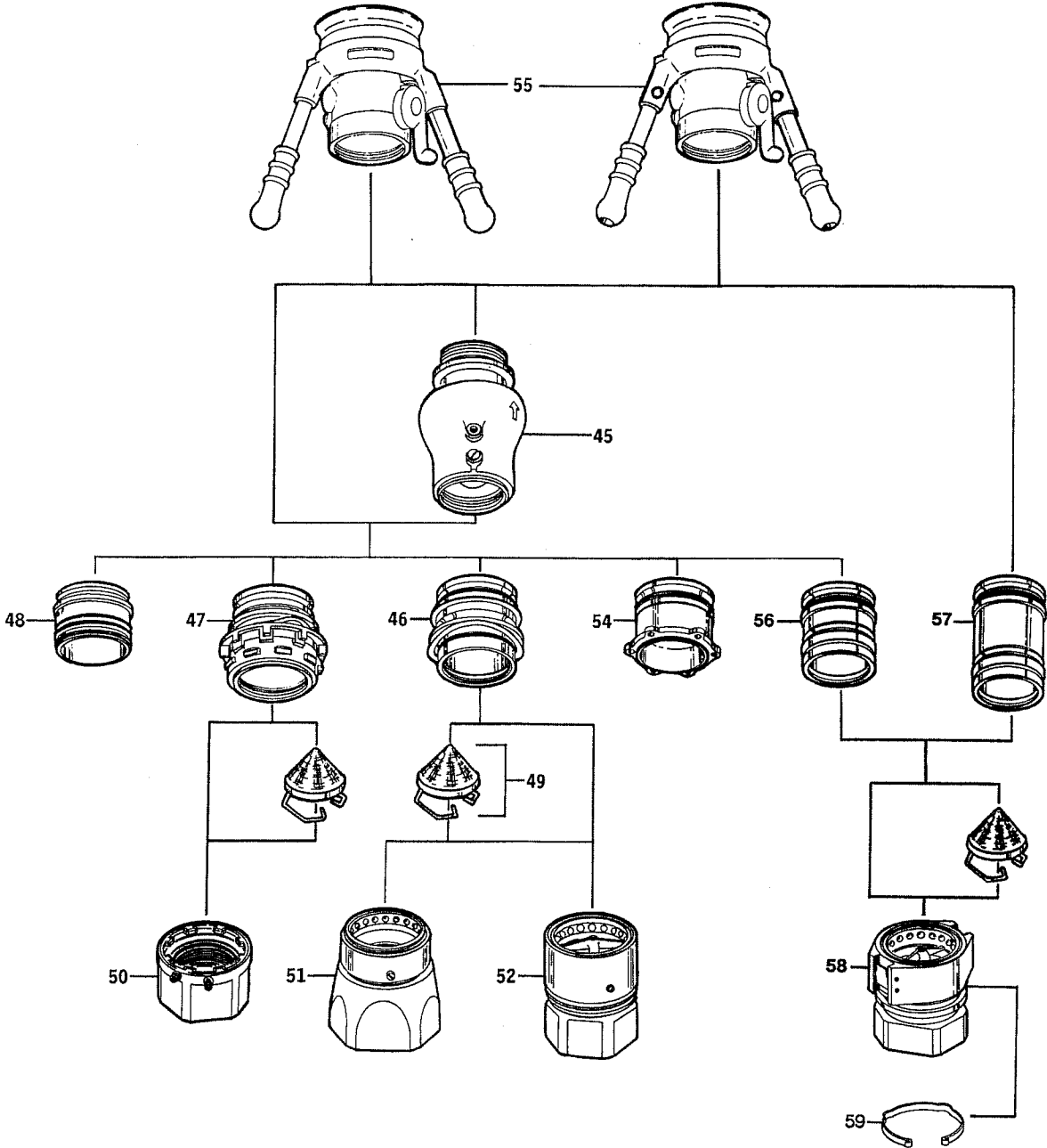

FIGURE 1

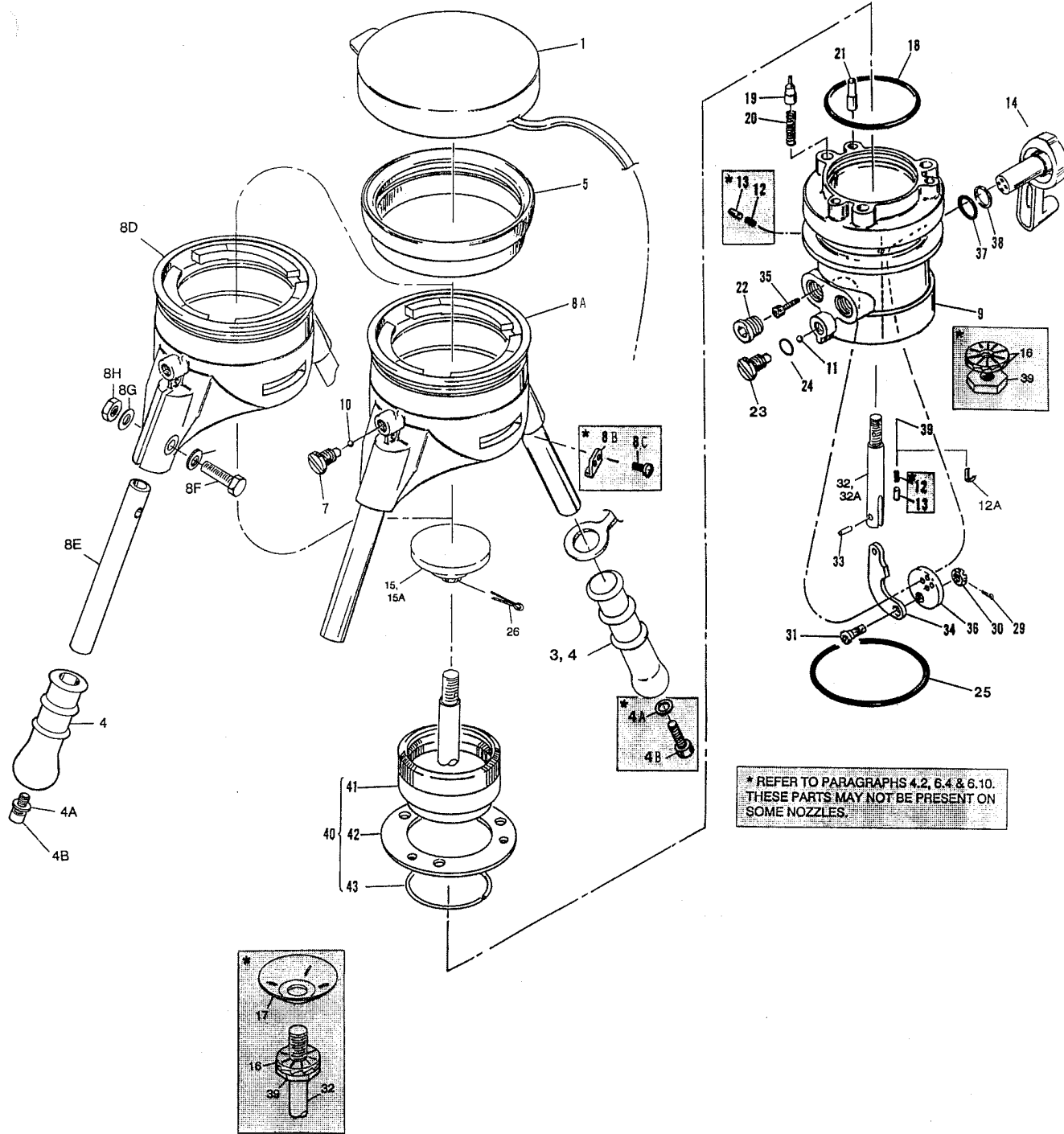

FIGURE 2

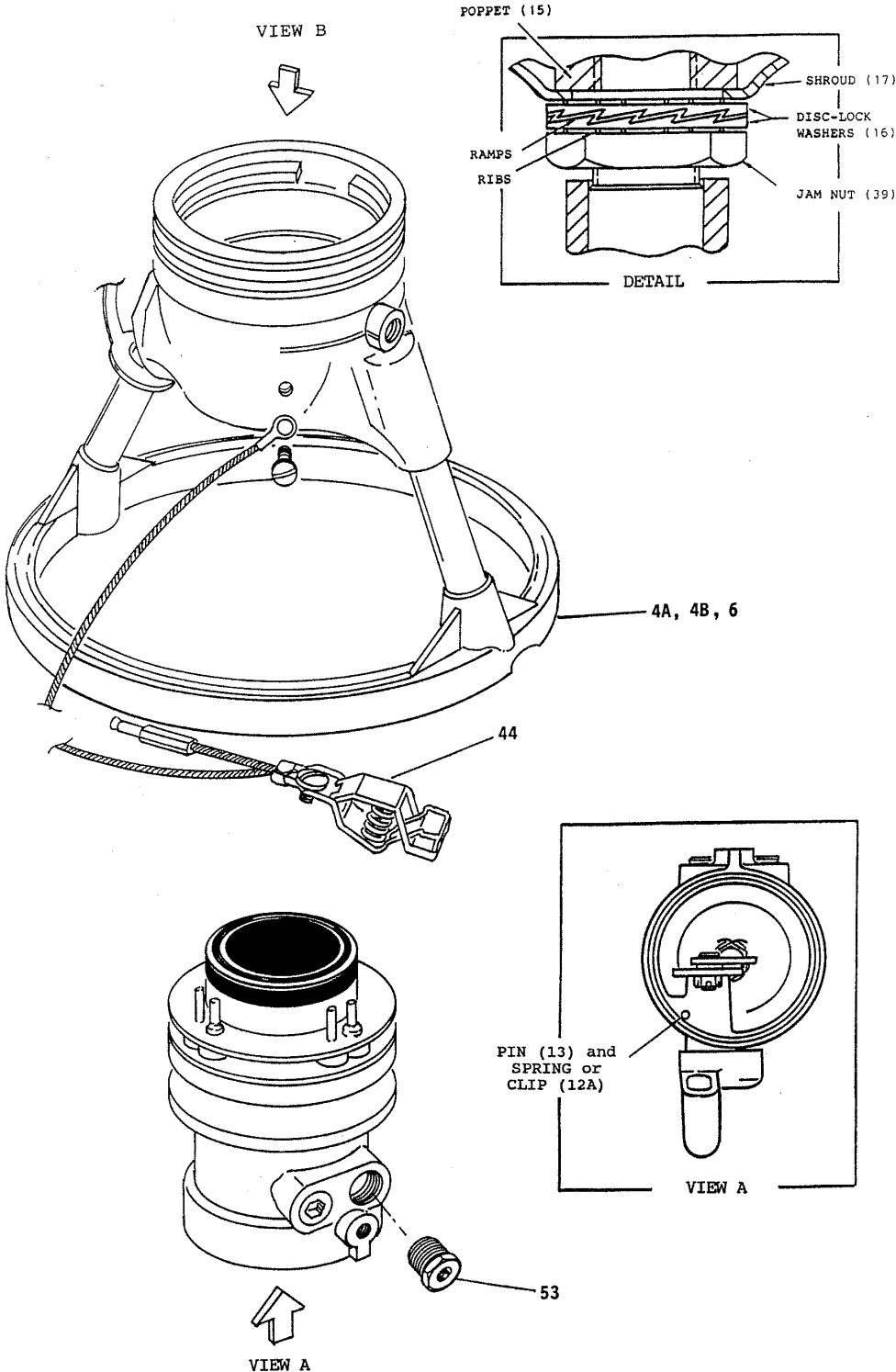

FIGURE 3

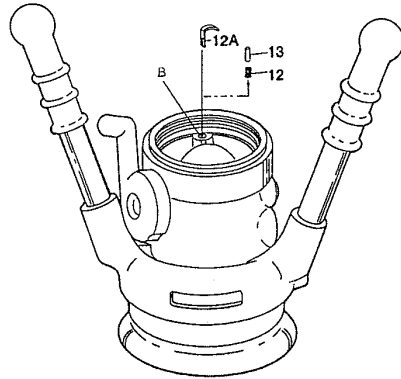

FIG. 4A
CONTINUITY CLIP (12A) INSTALLATION

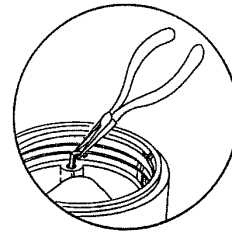
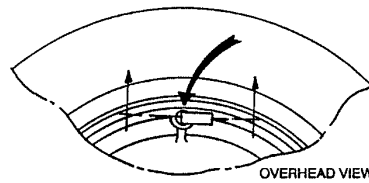

FIG. 4B
REMOVING CLIP (12A)



OVERHEAD VIEW

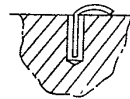

FIG. 4C

CORRECT CLIP (12A) INSTALLATION

FIGURE 4

Aerospace Group
Conveyance Systems Division
9650 Jeronimo Rd
Irvine, CA 92618
Ph (949) 452-9500
Fax (949) 452-9992